

COMPILERS

Register Allocation

hussein suleman
uct csc3005h 2006

Register Allocation

- Want to maximise use of registers for temporaries.
- Build interference graph for each program point.
 - Compute set of temporaries simultaneously live.
 - Add edge to graph for each pair in set.
- Then K-colour the graph by assigning a maximum of K colours such that interfering variables always have different colours.

Step 1: Build

- Start with final live sets from liveness analysis. Add an edge for each pair of simultaneously live variables to interference graph.
- Add a dotted line for any "MOVE a,b" instructions

	out	in
a←1	a	-
b←2	ab	a
c←a+b	ac	ab
b←c	ac	ac
d←a+c	ad	ac
d←a+d	-	ad

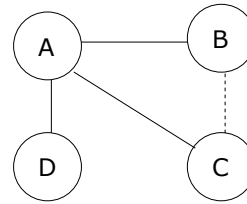

code and liveness analysis

interference graph (assume K=2)

Step 2: Simplify

- Remove any non-MOVE-related nodes with degree < K and place on stack.
 - K-colourability is maintained in the new subgraph.
 - Every node removed is guaranteed a colour.
 - The removal of edges may create other <K degree nodes.

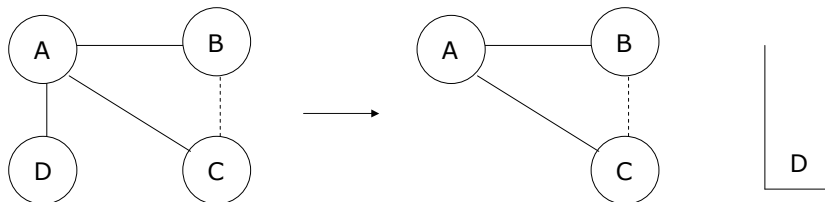

Step 3: Coalesce

- Merge together MOVE-related nodes if it does not decrease colourability.
 - Briggs: only if merged node ab has $<K$ significant degree neighbours
 - George: only if all significant degree neighbours of a interfere with b

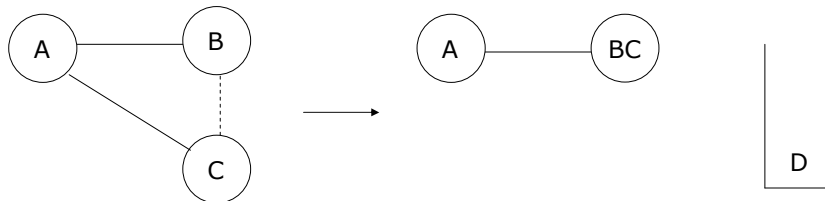

And Repeat ...

- Simplify again



- And simplify again

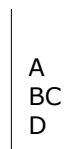

Step 6: Select

- Pop nodes off stack and assign colours/registers.

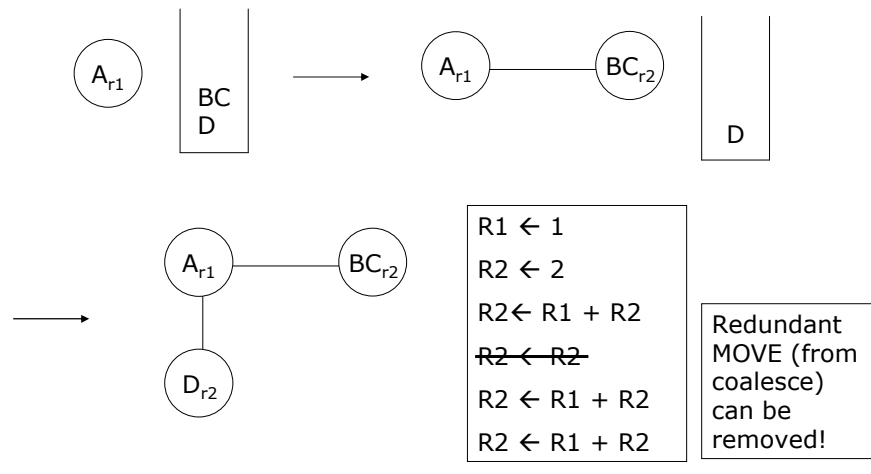

Step 4: Freeze

- If there are no nodes that can be simplified or coalesced AND there are MOVE-related nodes, freeze all MOVES of a low-degree MOVE-related node.
 - Ignore the MOVE and treat the nodes like any others.
- Repeat steps 2-3-4

Step 5: Potential Spill

- If there are no nodes that can be simplified, coalesced or frozen, choose a node that isn't used much in the program and spill it.
 - Add it to the stack just like a simplify.
 - There may or may not be a colour to allocate to it during the Select step – if there isn't, the potential spill becomes an actual spill.

- Repeat steps 2-3-4-5

Actual Spills

- An actual spill is when there aren't enough registers to store the temporaries.
- Rewrite program to shorten live range of spilled variable.
 - Move variable to memory after define.
 - Move memory to variable before use.
- Then, repeat process from Step 1.

$c \leftarrow a$		$c_1 \leftarrow a$
.		$\text{Mem}_c \leftarrow c_1$
.	\longrightarrow	.
.		$c_2 \leftarrow \text{Mem}_c$
$b \leftarrow c+1$		$b \leftarrow c_2 + 1$

Spilled Temporaries

- Spilled temporaries can be graph-coloured to reuse activation record slots.
 - Coalescing can be aggressive, since (unlike registers) there is no limit on the number of stack-frame locations.
 - Aggressive coalescing: Any non-interfering nodes can be coalesced since there is no upper bound K .

Precoloured Nodes

- Precoloured nodes correspond to machine registers (e.g., stack pointer, arguments)
 - Select and Coalesce can give an ordinary temporary the same colour as a precoloured register, if they don't interfere
 - e.g., argument registers can be reused inside procedures for a temporary
 - Simplify, Freeze and Spill cannot be performed on them
- Precoloured nodes interfere with other precoloured nodes.

Temporary Copies

- Since precoloured nodes don't spill, their live ranges must be kept short:
 - Use MOVE instructions.
 - Move callee-save registers to fresh temporaries on procedure entry, and back on exit, spilling between as necessary.
 - Register pressure will spill the fresh temporaries as necessary, otherwise they can be coalesced with their precoloured counterpart and the moves deleted.

Handling CALL instructions

- Variables whose live ranges span calls should go to callee-save registers, otherwise to caller-save.
- This is easy for graph coloring allocation with spilling
 - Calls define (interfere with) caller-save registers.
 - Calls use parameter registers.
 - A variable that is alive before and after a call interferes with all precoloured caller-save registers, as well as with the fresh temporaries created for callee-save copies, forcing a spill.
 - Choose nodes with high degree but few uses, to spill the fresh callee-save temporary instead of the cross-call variable. This makes the original callee-save register available for colouring the cross-call variable

Example

```

1  f:  c ← r3
2      p ← r1
3      if p=0 goto L1
4      r1 ← M[p]
5      call f
6      s ← r1
7      r1 ← M[p+4]
8      call f
9      t ← r1
10     u ← s + t
11     goto L2
12 L1: u ← 1
13 L2: r1 ← u
14     r3 ← c
15     return

```

- 3 Machine registers (K=3)
- Caller-save:
 - r1, r2
- Callee-save:
 - r3
- CALL parameters are set in r1 and results are returned in r1

Example: Liveness Analysis

#	Statement	Succ	Use	Def	Out	In
1	f: c ← r3	2	r3	c	cr1	r1r3
2	p ← r1	3	r1	p	cp	cr1
3	if p=0 goto L1	4,12	p		cp	cp
4	r1 ← M[p]	5	p	r1	cpr1	cp
5	call f	6	r1	r1r2	cpr1	cpr1
6	s ← r1	7	r1	s	cps	cpr1
7	r1 ← M[p+4]	8	p	r1	cpr1	cps
8	call f	9	r1	r1r2	csr1	csr1
9	t ← r1	10	r1	t	cst	csr1
10	u ← s + t	11	st	u	cu	cst
11	goto L2	13			cu	cu
12	L1: u ← 1	13		u	cu	c
13	L2: r1 ← u	14	u	r1	cr1	cu
14	r3 ← c	15	c	r3	r1r3	cr1
15	return		r1r3			r1r3

Example: Edge Determination

- Calculate live pairs based on liveness sets:
 - liveness sets: $cp1, cps, csr1, cst, cu$
 - edges $\supseteq \{cp, cr1, cs, ct, cu, pr1, ps, sr1, st\}$
- For each CALL, the variables that are live-in and also live-out must interfere with all caller-save registers ($r1r2$).
 - cp is live-in and live-out in line 5, cs in line 8
 - edges $\supseteq \{cp, cs, cr1, cr2, pr1, pr2, sr1, sr2\}$
- Create pairs of precoloured nodes (e.g., machine registers).
 - edges $\supseteq \{r1r2, r2r3, r1r3\}$
- Determine move instructions that are not already constrained.
 - moves = $\{cr3, tr1, ur1\}$ (constrained = $\{pr1, sr1\}$)

Example 1

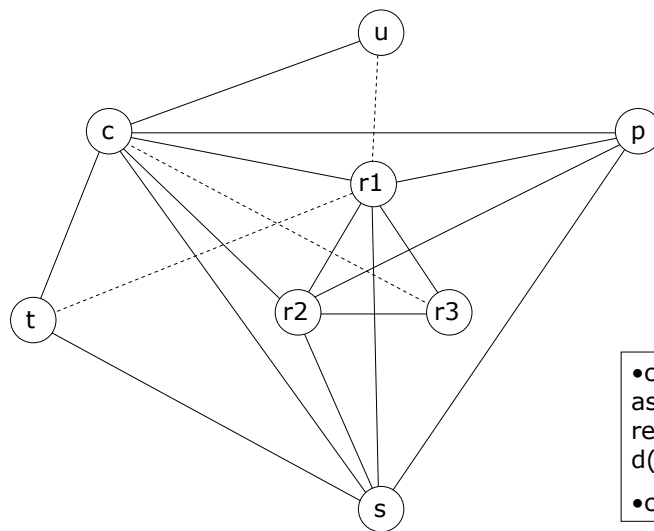

Example 2

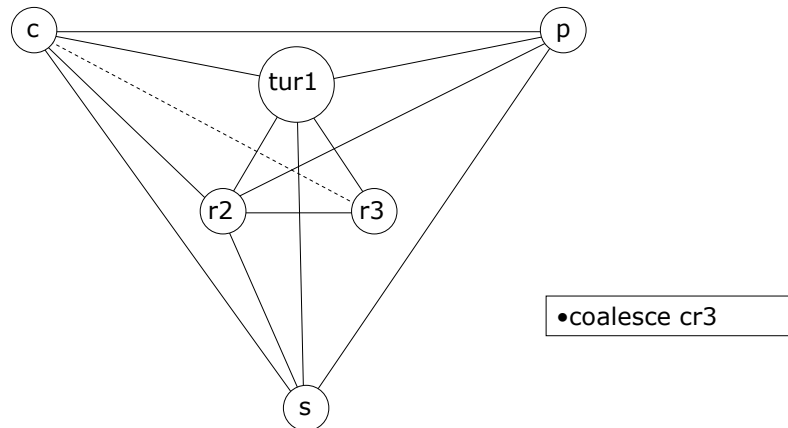

Example 3

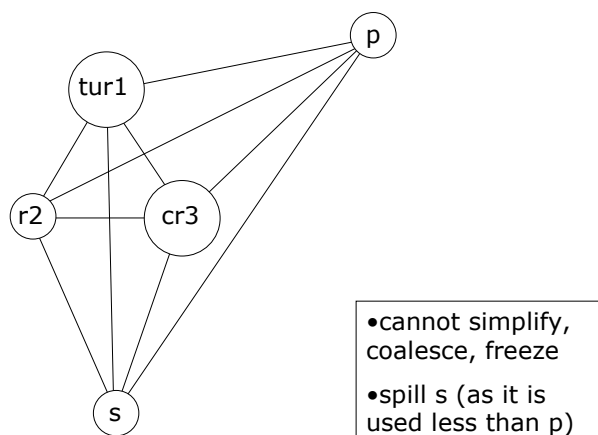

Example 4

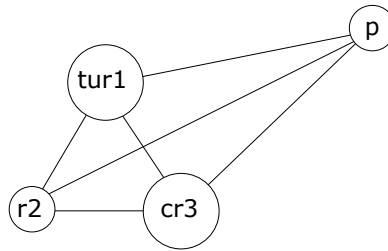

s*

- cannot simplify, coalesce, freeze
- spill p

Example 5

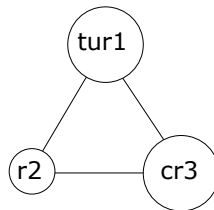

p*
s*

- cannot remove precoloured nodes
- select to put back nodes and colour
- add p

Example 6

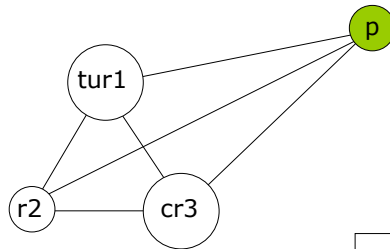

s*

- cannot colour p
- p is an actual spill – do not colour it
- add potential spill s

Example 7

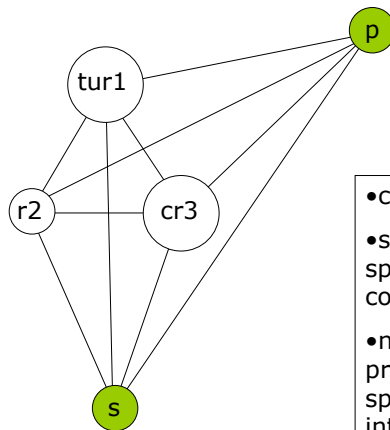

c*

- cannot colour s
- s in an actual spill – do not colour it
- now rewrite program to handle spills and build interference graph

Example Rewritten

#	Statement	Succ	Use	Def	Out	In
1	f: c ← r3	2	r3	c	cr1	r1r3
2	p1 ← r1	3	r1	p	cp1	cr1
3	Mp ← p1	4	p1		c	cp1
4	p2 ← Mp	5		p2	cp2	c
5	if p2=0 goto L1	6,18	p2		c	cp2
6	p3 ← Mp	7		p3	cp3	c
7	r1 ← M[p3]	8	p3	r1	cr1	cp3
8	call f	9	r1	r1r2	cr1	cr1
9	s1 ← r1	10	r1	s1	cs1	cr1
10	Ms ← s1	11	s1		c	cs1
11	p4 ← Mp	12		p4	cp4	c
12	r1 ← M[p4+4]	13	p4	r1	cr1	cp4
13	call f	14	r1	r1r2	cr1	cr1
14	t ← r1	15	r1	t	ct	cr1
15	s2 ← Ms	16		s2	cs2t	ct
16	u ← s2 + t	17	s2t	u	c	cs2t
17	goto L2	18			c	c
18	L1: u ← 1	19		u	cu	c
19	L2: r1 ← u	20	u	r1	cr1	cu
20	r3 ← c	21	c	r3	r1r3	cr1
21	return		r1r3			r1r3

Example: Edge Determination B

- Calculate live pairs based on liveness sets:
 - liveness sets: cr1, cp1, cp2, cp3, cs1, cp4, cs2t, cu
 - edges \supseteq {cr1, cp1, cp2, cp3, cs1, cp4, cs2, ct, s2t, cu}
- For each CALL, the variables that are live-in and also live-out must interfere with all caller-save registers (r1r2).
 - c is live-in and live-out in line 8 and in line 13
 - edges \supseteq {cr1, cr2}
- Create pairs of precoloured nodes (e.g., machine registers).
 - edges \supseteq {r1r2, r2r3, r1r3}
- Determine move instructions that are not already constrained.
 - moves = {p1r1, s1r1, tr1, ur1, cr3}

Example 1B

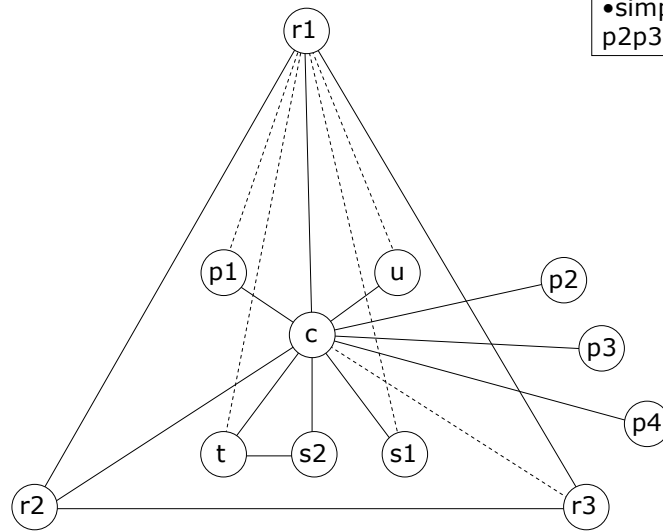

Example 2B

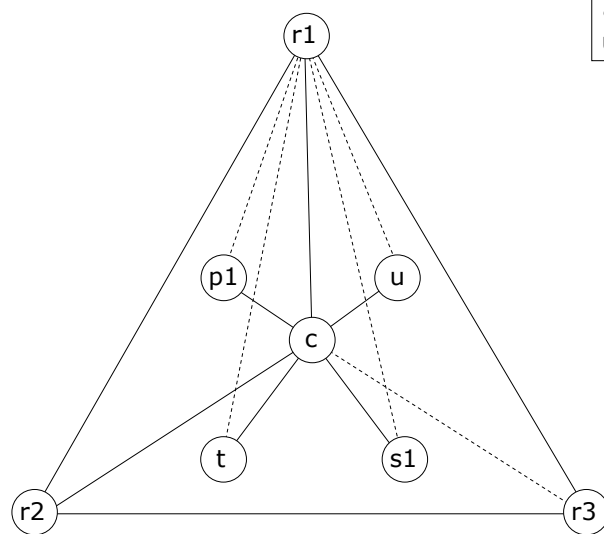

Example 3B

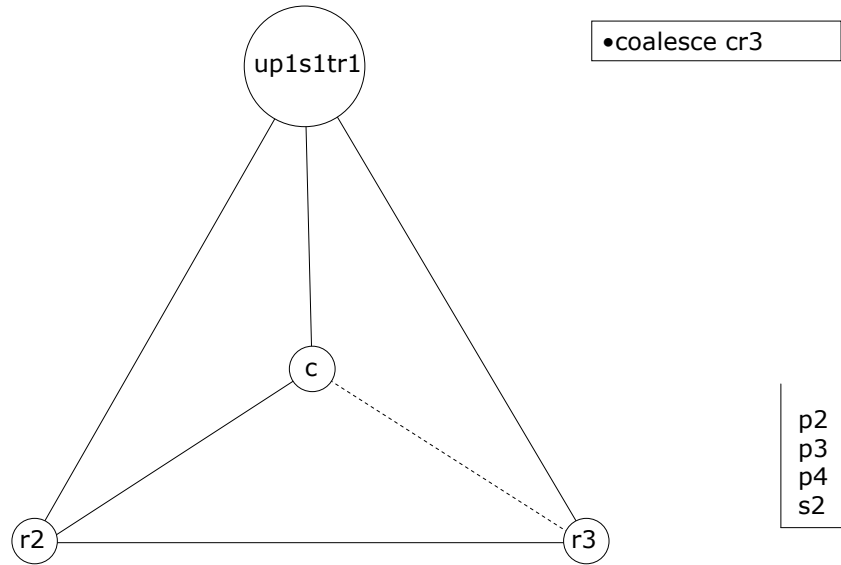

Example 4B

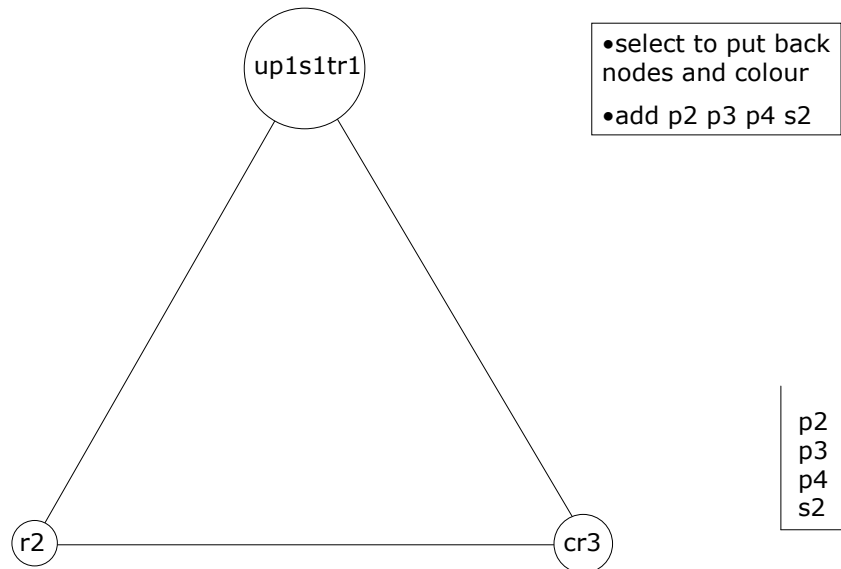

Example 5B

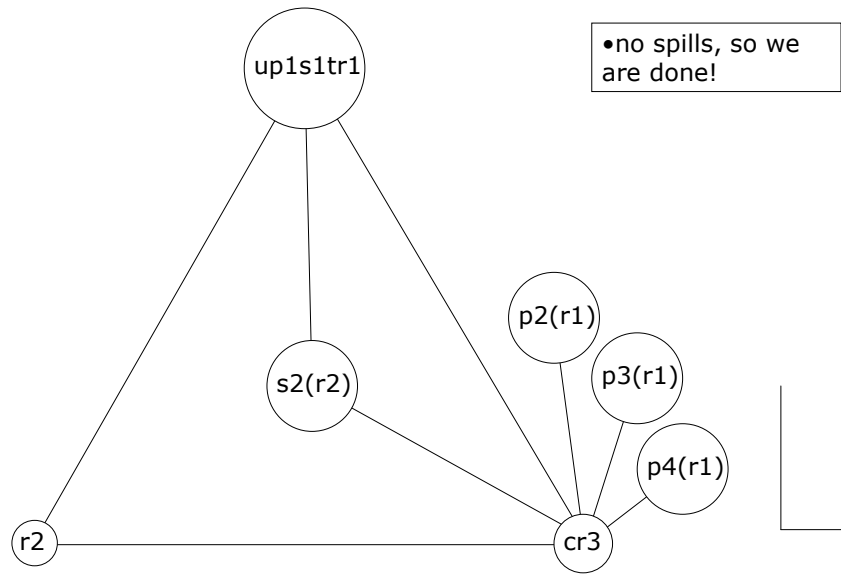

Final Register Allocation

```
f: r3 ← r3
   r1 ← r1
   Mp ← r1
   r1 ← Mp
   if r1=0 goto L1
   r1 ← Mp
   r1 ← M[r1]
   call f
   r1 ← r1
   Ms ← r1
   r1 ← Mp
   r1 ← M[r1+4]
   call f
   r1 ← r1
   r2 ← Ms
   r1 ← r2 + r1
   goto L2
L1:r1 ← 1
L2:r1 ← r1
   r3 ← r3
   return
```

eliminate
MOVes with the
same source
and destination

```
f: Mp ← r1
   r1 ← Mp
   if r1=0 goto L1
   r1 ← Mp
   r1 ← M[r1]
   call f
   Ms ← r1
   r1 ← Mp
   r1 ← M[r1+4]
   call f
   r2 ← Ms
   r1 ← r2 + r1
   goto L2
L1:r1 ← 1
L2:return
```